

OPzS Deep Cycle Tubular Flooded Battery

40PzS200

CSBattery OPzS series is flooded Lead Acid battery that adopts Tubular Plate technology to offer high reliability and performance. The Battery is designed and manufactured according to standards and with DIN40736-2/IEC60896-11 positive spine and patent formula of die-casting active material. OPzS series exceeds standard values with more DIN40736-2/IEC60896-11 than 20 years floating design even more suitable for life at 25°C and is cyclic use(PV/solar, traction etc) under extreme operating conditions.

2V
250Ah

Flooded
Technology

Tubular
Plate



Applications

- Solar & Wind Power system
- Nuclear power station
- Telecom backup power supply
- energy saving requirements
Emergency Power System

General Features

- ✓ It can discharge at -40°C-70°C, Charge at 0-50°C
- ✓ Long life expectancy of 20+ years in floating condition
- ✓ Adopts quality silicon nano gel electrolyte
- ✓ Excellent deep discharge recovery capability
- ✓ Deep cycle performance: up to 3300

Dimensions & Weight

Technical Specifications

Unit: mm

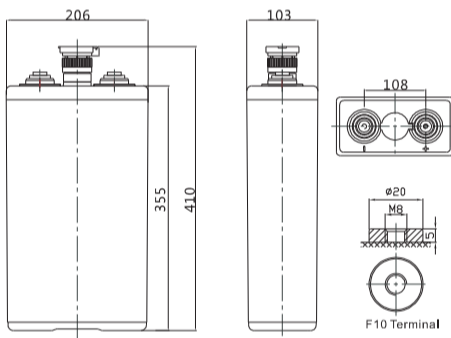

Length	103±2mm (4.01 inches)
Width	206±2mm (8.11 inches)
Height	355±2mm (14.0 inches)
Total Height	410±2mm (16.1 inches)
Torque Value	10~12 N*m

Cells Per Unit	1
Voltage Per Unit	2
Nominal Capacity	200Ah@10hr-rate to 1.80V per cell @25°C
Weight	Without Electrolyte 13.3kg/With Electrolyte 17.6kg
Internal Resistance	Approx. 0.95 mΩ
Terminal	F10(M8)
Max. Discharge Current	1000A (5 sec)
Design Life	20 years (floating charge)
Max. Charging Current	30.0 A
Reference Capacity	C3 162.6AH C5 181.0AH C10 200.0AH C20 242.0AH
Float Charging Voltage	2.23 V~2.25 V @ 25°C Temperature Compensation: -3mV/°C/Cell
Cycle Use Voltage	2.40 V~2.45 V @ 25°C Temperature Compensation: -4mV/°C/Cell
Operating Temperature Range	Discharge: -15°C~50°C Charge: 0°C~40°C Storage: -15°C~50°C
Normal Operating Temperature Range	25°C ±5°C
Self Discharge	OPzS series is flooded Lead Acid battery . It can be stored for up to 2 years before filling acid. Monthly Self-discharge ratio is less than 3.5% at 20°C .Please charged batteries before using.
Container Material	A.B.S. UL94-HB, UL94-V0 Optional.

Battery Discharge Table

Discharge Constant Current per Cell (Amperes at 25° C)

F.V/ Time	30min	1h	2h	3h	4h	5h	6h	8h	10h	20h
1.60V	211.0	136.1	80.6	58.7	45.3	37.9	33.1	26.0	21.9	12.6
1.65V	204.6	128.1	78.0	57.3	44.6	37.4	32.6	25.8	21.7	12.5
1.70V	189.0	124.1	75.8	55.9	43.9	36.9	32.2	25.6	21.5	12.3
1.75V	169.6	115.9	72.5	54.2	43.1	36.2	31.6	25.2	21.1	12.1
1.80V	153.1	103.3	67.2	50.9	41.2	34.6	30.2	24.0	20.0	11.5
1.85V	127.7	88.6	60.1	46.2	38.1	32.0	28.0	22.4	18.7	10.8

Discharge Constant Power per Cell (Watts at 25° C)

F.V/ Time	30min	1h	2h	3h	4h	5h	6h	8h	10h	20h
1.60V	357.0	232.2	147.3	110.0	87.5	73.5	64.2	51.0	43.5	25.0
1.65V	351.0	222.3	143.4	107.8	86.4	72.7	63.6	50.6	43.3	24.9
1.70V	333.3	220.1	139.9	105.6	85.0	71.7	63.0	50.1	42.9	24.7
1.75V	307.3	210.7	135.5	103.2	83.9	70.7	61.9	49.5	42.3	24.3
1.80V	285.1	193.0	127.1	97.8	80.4	67.8	59.5	47.6	40.5	23.3
1.85V	244.4	170.0	116.1	89.9	74.5	62.9	55.4	44.9	38.2	22.0

OPzS Deep Cycle Tubular Flooded Battery 40PzS200

Performance Characteristics

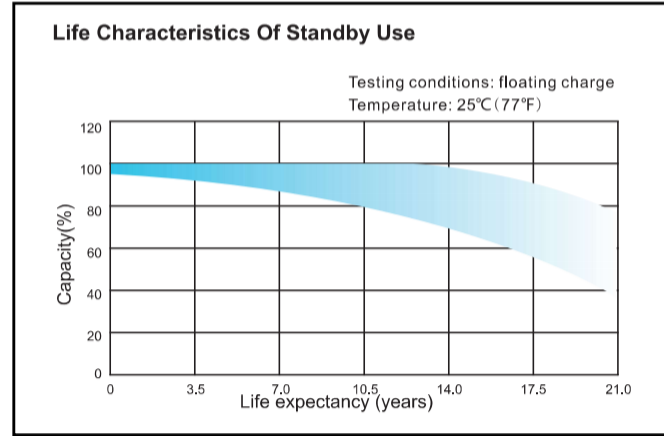
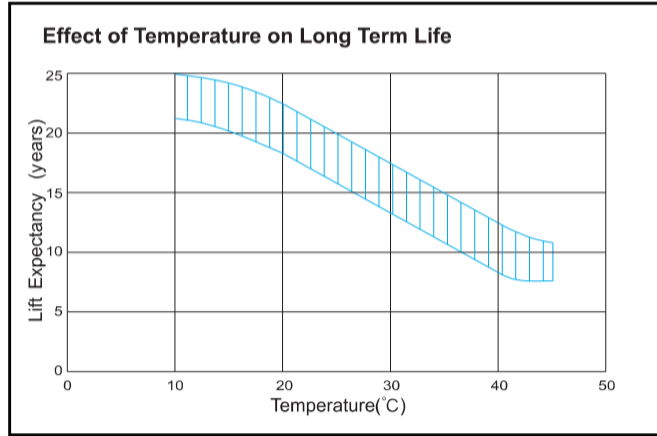
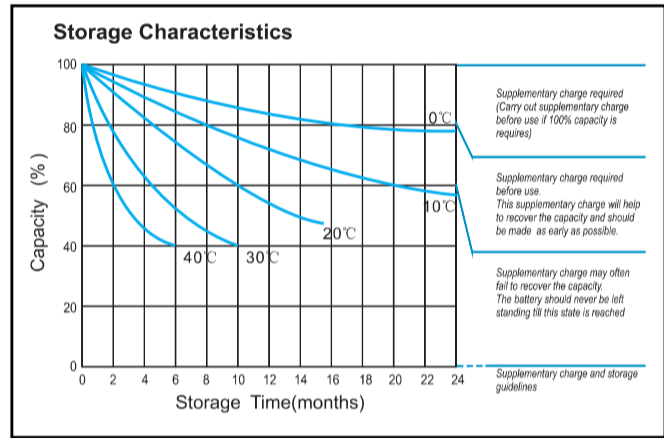
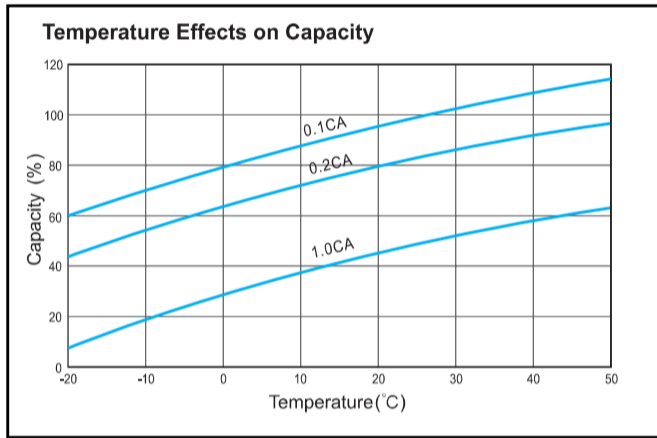
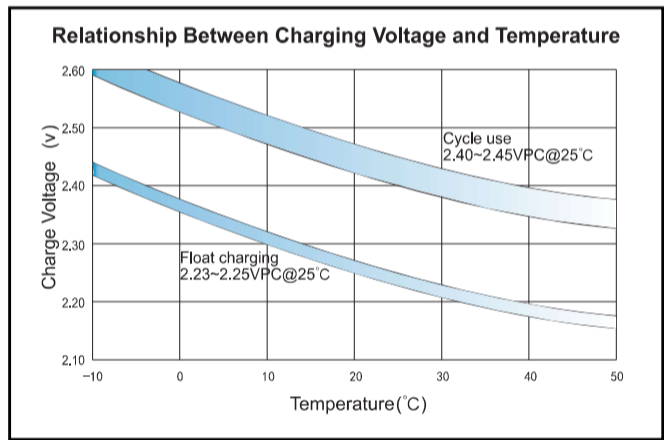
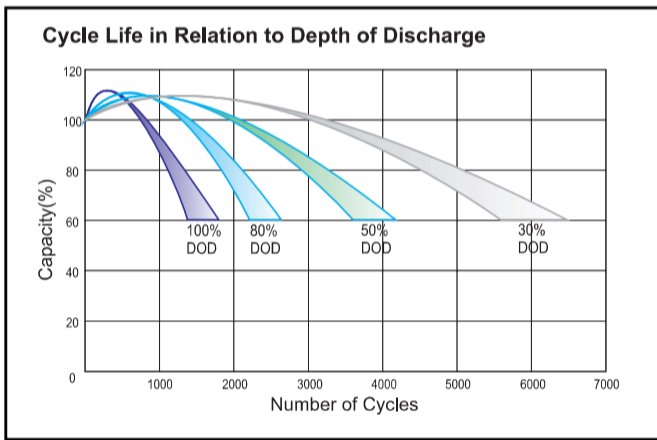
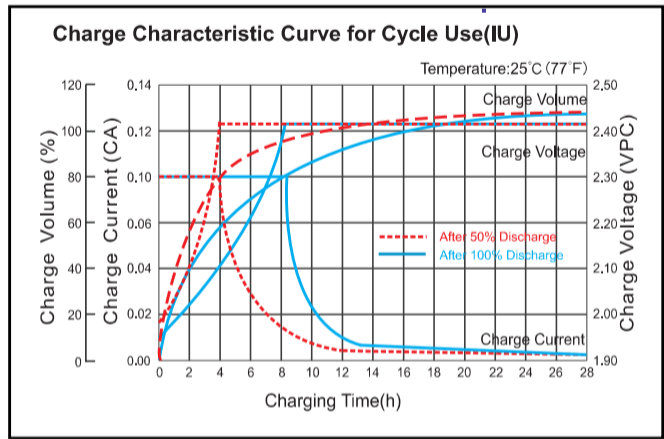
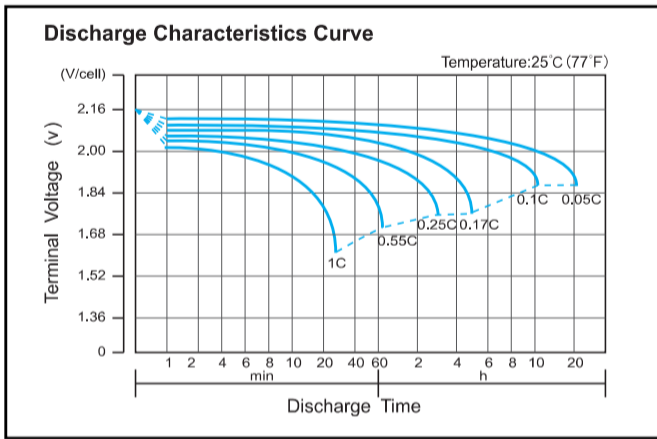

Note: The above data are average values, and can be obtained within 3 charge/discharge cycles. These are not minimum values. Cell and battery designs/specifications are subject to modification without notice. Contact **CSBattery** for the latest information.

Add: Building Evolution, Xingdong industry Park, NO.61, Liuxian 2nd Road, Baoan, Shenzhen, China.

Tel: +86-755-29123661 Email: Sales@CSBattery.cn, Support@CSBattery.cn

Website: www.CSBattery.cn