

OPzS Deep Cycle Tubular Flooded Battery 70PzS490

CSBattery OPzS series is flooded Lead Acid battery that adopts Tubular Plate technology to offer high reliability and performance. The Battery is designed and manufactured according to standards and with DIN40736-2/IEC60896-11 positive spine and patent formula of die-casting active material. OPzS series exceeds standard values with more DIN40736-2/IEC60896-11 than 20 years floating design even more suitable for life at 25°C and is cyclic use(PV/solar, traction etc) under extreme operating conditions.

2V
490Ah

Flooded
Technology

Tubular
Plate



Applications

- Solar & Wind Power system
- Nuclear power station
- Telecom backup power supply
- energy saving requirements
Emergency Power System

General Features

- ✓ It can discharge at -40°C~70°C, Charge at 0-50°C
- ✓ Long life expectancy of 20+ years in floating condition
- ✓ Adopts quality silicon nano gel electrolyte
- ✓ Excellent deep discharge recovery capability
- ✓ Deep cycle performance: up to 3300

Dimensions & Weight

Technical Specifications

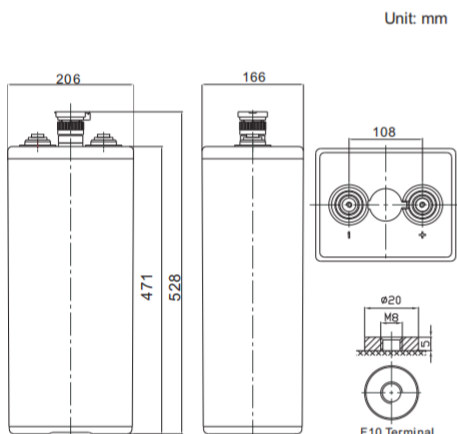

Length	166±1mm (6.54 inches)
Width	206±1mm (8.11 inches)
Height	471±1mm (18.5 inches)
Total Height	528±1mm (20.8 inches)
Torque Value	10~12 N*m

Cells Per Unit	1
Voltage Per Unit	2
Nominal Capacity	490Ah@10hr-rate to 1.85V per cell @25°C
Weight	Without Electrolyte 28.0kg/With Electrolyte 38.7kg
Internal Resistance	Approx. 0.50 mΩ
Terminal	F10(M8)
Max. Discharge Current	2000A (5 sec)
Design Life	20 years (floating charge)
Maximum Charging Current	73.5 A
Reference Capacity	C24 598.5AH C48 625.0AH C72 650.0AH C100 675.0AH C120 700.0AH C240 725.0AH
Float Charging Voltage	2.23 V~2.25 V @ 25°C Temperature Compensation: -3mV/°C/Cell
Cycle Use Voltage	2.40 V~2.45 V @ 25°C Temperature Compensation: -4mV/°C/Cell
Operating Temperature Range	Discharge: -15°C~50°C Charge: 0°C~40°C Storage: -15°C~50°C
Normal Operating Temperature Range	25°C ±5°C
Self Discharge	Valve Regulated Lead Acid (VRLA) batteries can be stored for up to 6 months at 25°C and then recharging is recommended. Monthly Self-discharge ratio is less than 3.5% at 25°C. Please charged batteries before using.
Container Material	A.B.S. UL94-HB, UL94-V0 Optional.

Battery Discharge Table

Discharge Constant Current per Cell (Amperes at 25° C)

F.V/ Time	30min	1h	2h	3h	4h	5h	6h	8h	10h	20h
1.90V	266.0	210.9	148.7	113.3	89.78	79.80	69.83	54.49	46.73	26.87
1.87V	297.4	232.5	159.5	120.7	94.76	84.40	74.03	57.04	48.83	28.07
1.83V	340.7	259.6	173.0	129.1	99.75	88.20	76.65	59.58	50.93	29.29
1.80V	378.5	281.2	179.5	132.9	101.7	90.24	78.75	61.11	52.50	30.19
1.75V	421.8	301.2	187.6	137.1	103.4	91.87	80.33	62.13	53.55	30.79
1.70V	465.0	310.9	193.0	140.4	105.2	93.30	81.38	62.64	54.08	31.10
1.65V	479.6	330.4	199.5	143.9	106.7	94.59	82.43	63.15	54.60	31.40
1.60V	500.2	341.8	207.1	148.7	109.7	96.60	83.48	63.66	55.13	31.70

Discharge Constant Power per Cell (Watts at 25° C)

F.V/ Time	30min	1h	2h	3h	4h	5h	6h	8h	10h	20h
1.90V	509.2	404.9	287.5	220.4	175.7	156.9	138.1	109.0	95.23	54.76
1.87V	560.3	439.7	304.9	233.1	185.2	165.6	146.0	113.6	99.30	57.10
1.83V	627.7	479.3	324.4	246.3	194.2	172.4	150.7	117.6	102.9	59.14
1.80V	685.8	511.4	335.3	252.8	197.9	176.1	154.4	120.2	105.4	60.61
1.75V	744.0	534.2	346.2	258.8	200.5	178.7	157.0	121.7	106.9	61.49
1.70V	797.8	539.6	354.9	264.1	203.7	181.1	158.6	122.7	108.0	62.07
1.65V	811.4	563.6	364.7	269.6	206.3	183.1	160.1	123.7	108.5	62.37
1.60V	821.2	581.0	373.4	276.3	211.6	186.4	161.2	124.3	109.0	62.66

OPzS Deep Cycle Tubular Flooded Battery 70PzS490

Performance Characteristics

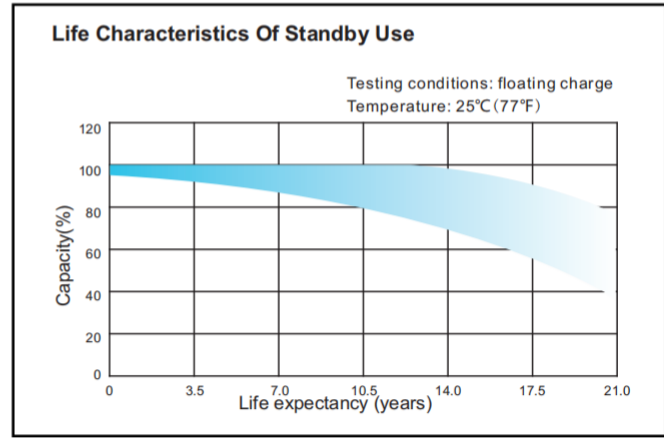
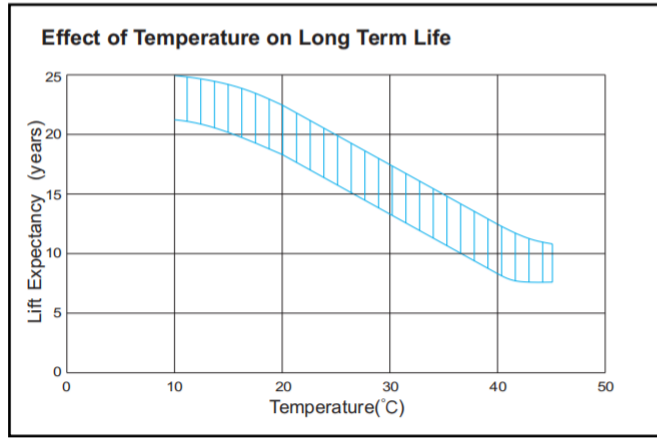
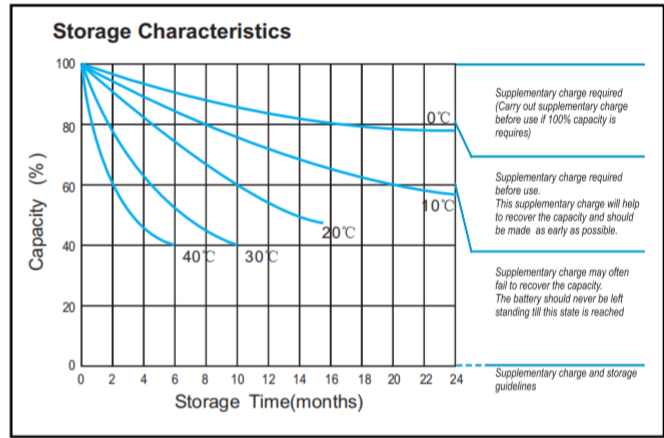
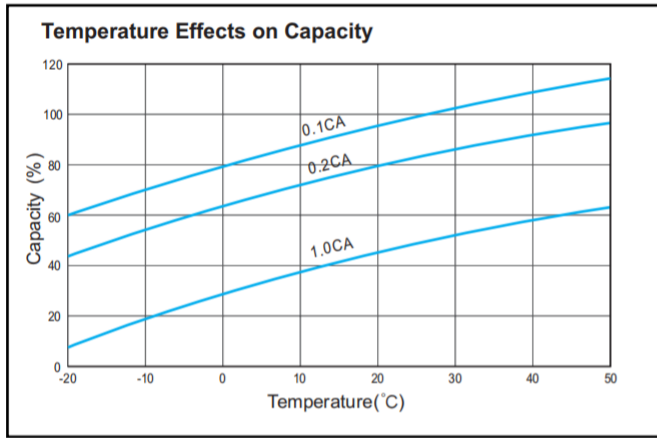
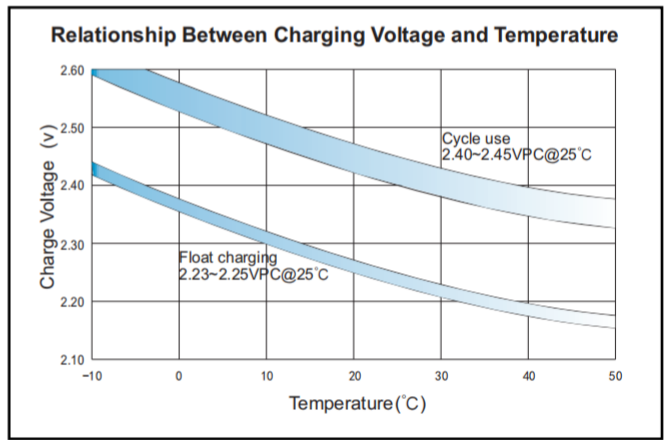
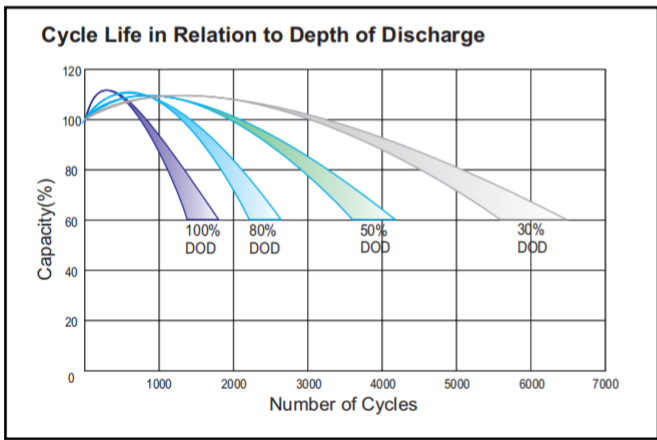
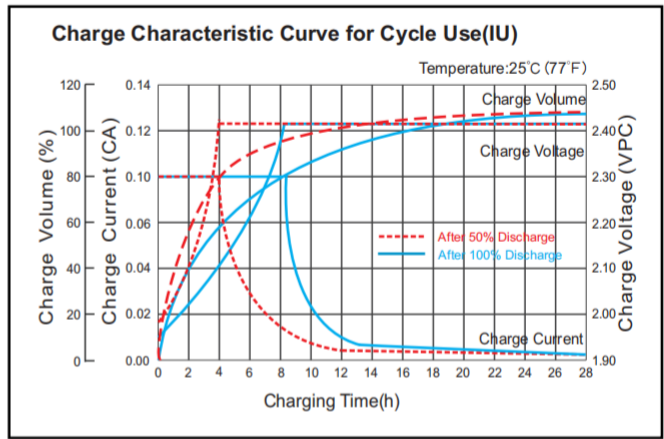
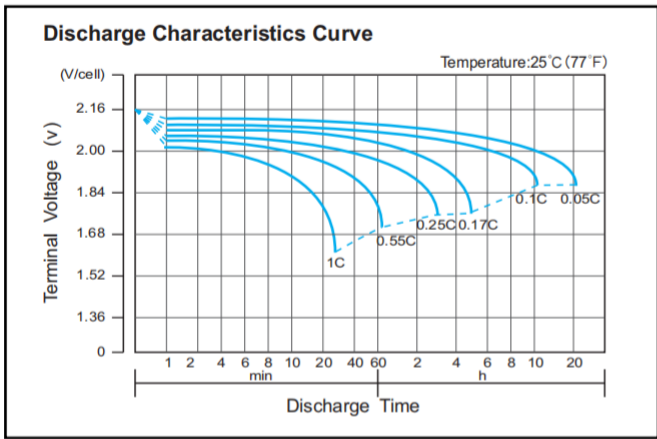

Note: The above data are average values, and can be obtained within 3 charge/discharge cycles. These are not minimum values. Cell and battery designs/specifications are subject to modification without notice. Contact **CSBattery** for the latest information.

Add: Building Evolution, Xingdong industry Park, NO.61, Liuxian 2nd Road, Baoan, Shenzhen, China.

Tel: +86-755-29123661 Email: Sales@CSBattery.cn, Support@CSBattery.cn

Website: www.CSBattery.cn