

Deep Cycle Long Life AGM Battery

DC12-135

CSBattery DC series deep cycle long life VRLA AGM battery uses a different chemistry additives in the positive plates and special AGM separators, The DC series features 70% higher cyclic life with 15 years of float life when compared to the standard Duration range. This series is highly suited for very unreliable power applications requiring the batteries to provide extra cyclic life performance such as PV system applications, small RE systems and electric vehicles.

12V
135Ah

AGM
Technology

Deep
Cycle



COMPLIED STANDARDS

IEC 60896-21/22 JIS C8704
YD/T799 ISO9001
GB/T 19638 CE

Applications

- Solar Systems
- Wheel chair, Golf Cart
- Telecom systems
- Cable TV Systems
- Emergency Power System

General Features

- Thicker plate with high Tin low Calcium alloy
- High Reliability and Good Quality
- Deep Discharge Recovery
- High Power Density
- Longer Service Life, in both Float or Cyclic

Dimensions & Weight

Length(mm)	341 ± 1
Width(mm)	173 ± 1
Height(mm)	283 ± 1
Total Height(mm)	288 ± 1
Weight(kg)	39.2 ± 3%

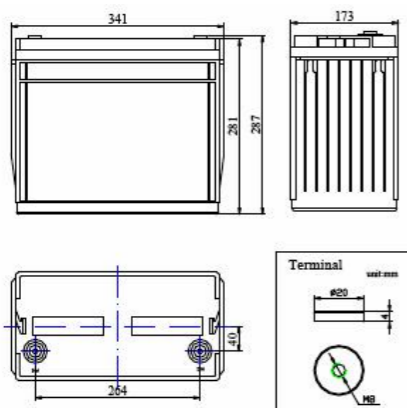

Technical Specifications

Nominal Voltage		12V(6 cells per unit)
Design Floating Life @25°C		15 Years
Nominal Capacity @25°C(20 hour rate@6.75A,10.8V)		135Ah
Capacity @25°C	10hour rate (12.2A,10.8V)	122Ah
	5 hour rate (21.5A,10.5V)	107.5Ah
	1 hour rate (78.0A,9.6V)	78.0Ah
Internal Resistance	Full Charged Battery@25°C	≤4.5mΩ
Ambient Temperature	Discharge	-15°C~45°C
	Charge	-15°C~45°C
	Storage	-15°C~45°C
Max.Discharge Current@25°C		700A(5s)
Capacity affected by Temperature (10 hour)	40°C	105%
	25°C	100%
	0°C	85%
	-15°C	65%
Self-Discharge@25°C per Month		3%
Charge (Constant Voltage) @25°C	Standby Use	Initial Charging Current Less than 27A Voltage 13.6-13.8V
	Cycle Use	Initial Charging Current Less than 27A Voltage 14.4-14.9V

Battery Discharge Table

Discharge Constant Current per Cell (Amperes at 25°C)

F.V/Time	15min	30min	45min	1h	2h	3h	5h	8h	10h	20h	100h
1.60V	210.9	125.5	89.1	78.0	47.6	33.4	22.7	15.0	13.4	7.29	1.62
1.65V	207.0	123.2	87.5	76.5	46.7	32.8	22.3	14.7	13.1	7.16	1.59
1.70V	203.2	120.9	85.9	75.1	45.9	32.2	21.9	14.5	12.9	7.02	1.56
1.75V	199.4	118.6	84.2	73.7	45.0	31.6	21.5	14.2	12.6	6.89	1.53
1.80V	191.7	114.1	81.0	70.9	43.3	30.4	20.7	13.6	12.2	6.75	1.50

Discharge Constant Power per Cell (Watts at 25°C)

F.V/Time	15min	30min	45min	1h	2h	3h	5h	8h	10h	20h	100h
1.60V	405.9	241.6	171.5	150.1	91.6	64.3	43.7	28.9	25.7	14.0	3.12
1.65V	398.5	237.2	168.4	147.3	90.0	63.1	42.9	28.3	25.3	13.8	3.06
1.70V	391.2	232.8	165.3	144.6	88.3	62.0	42.1	27.8	24.8	13.5	3.00
1.75V	383.8	228.4	162.2	141.9	86.6	60.8	41.4	27.3	24.3	13.3	2.94
1.80V	369.0	219.6	155.9	136.4	83.3	58.5	39.8	26.2	23.4	13.0	2.88

Note: The above data are average values, and can be obtained within 3 charge/discharge cycles. These are not minimum values. Cell and battery designs/specifications are subject to modification without notice. Contact **CSBattery** for the latest information.

Performance Characteristics

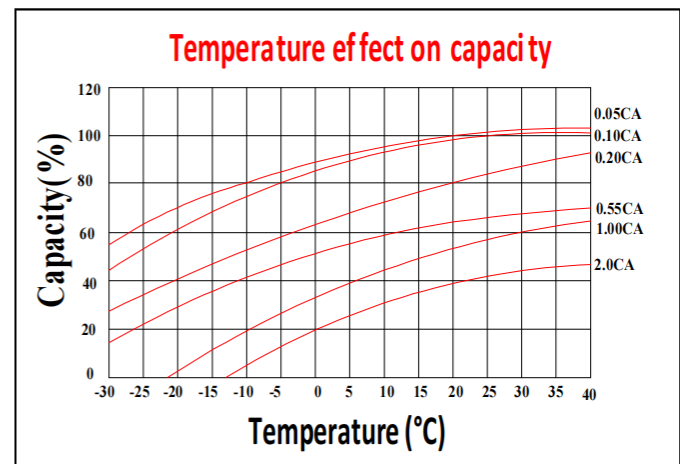
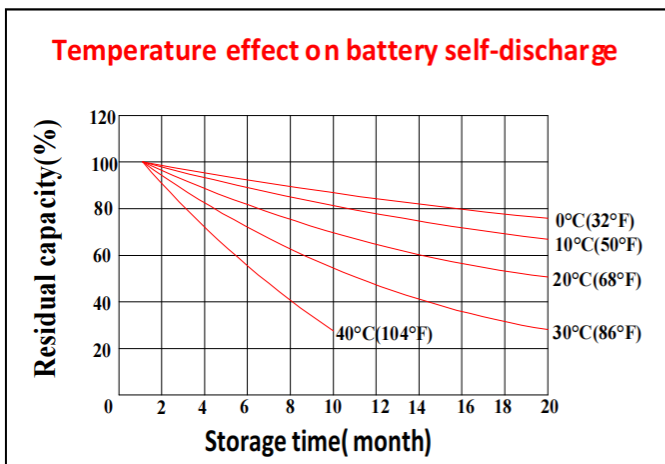
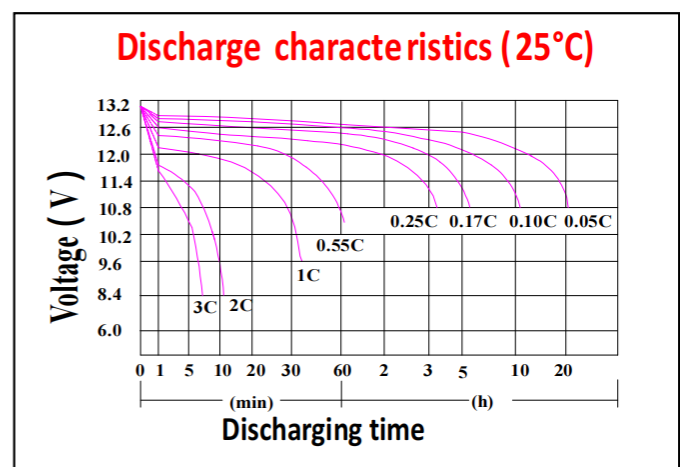
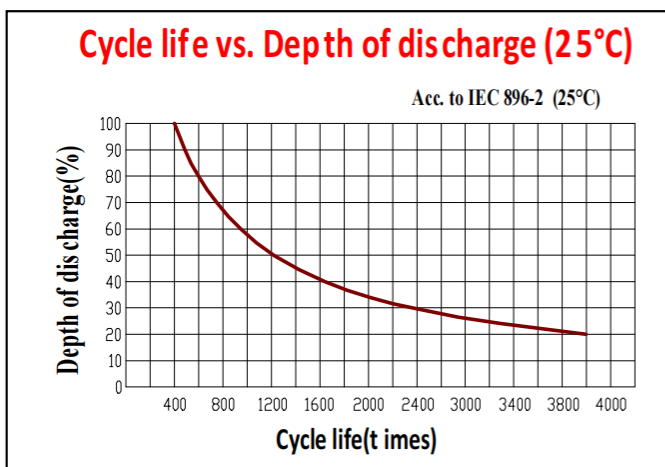
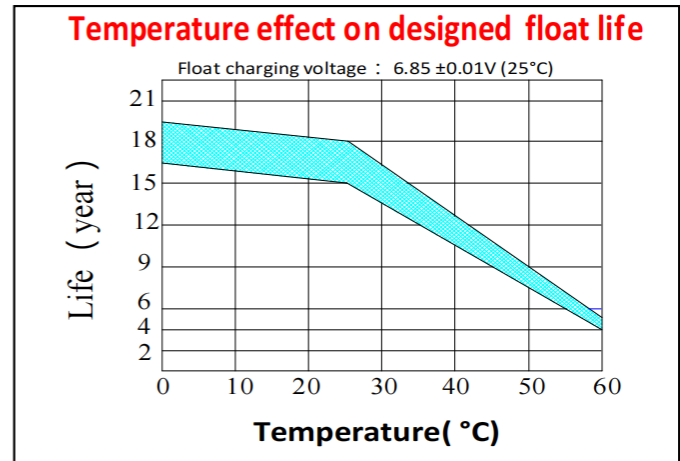
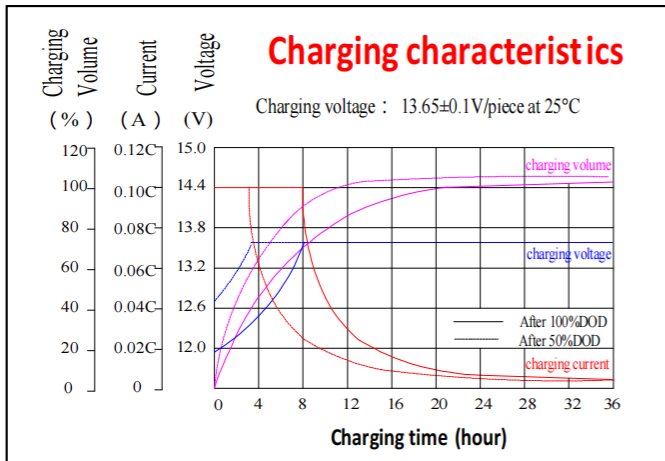

Battery Construction

Component	Positive plate	Negative plate	Container & Cover	Safety valve	Terminal	Separator	Electrolyte	Pillar seal
Features	Thick high Sn low Ca grid with special paste	Balanced Pb-Ca grid for improved recombination efficiency	Fire resistance ABS UL94-V0	Flame Si-Rubber and aging resister	Female Copper Insert M8(torque :10~11N.m)	Advanced AGM separator for high pressure cell design	Dilute high purity sulphuric acid	Two layers epoxy resin seal

Add: Building Evolution, Xingdong industry Park, NO.61, Liuxian 2nd Road, Baoan, Shenzhen, China.

Tel: +86-755-29123661 Email: Sales@CSBattery.cn, Support@CSBattery.cn

Website: www.CSBattery.cn

