

## OPzS Deep Cycle Tubular Flooded Battery

## 80PzS800

CSBattery OPzS series is flooded Lead Acid battery that adopts Tubular Plate technology to offer high reliability and performance. The Battery is designed and manufactured according to standards and with DIN40736-2/IEC60896-11 positive spine and patent formula of die-casting active material. OPzS series exceeds standard values with more DIN40736-2/IEC60896-11 than 20 years floating design even more suitable for life at 25°C and is cyclic use(PV/solar, traction etc) under extreme operating conditions.

2V  
800Ah

Flooded  
Technology

Tubular  
Plate



### Applications

- Solar & Wind Power system
- Nuclear power station
- Telecom backup power supply
- energy saving requirements  
Emergency Power System

### General Features

- ✓ It can discharge at -40°C-70°C, Charge at 0-50°C
- ✓ Long life expectancy of 20+ years in floating condition
- ✓ Adopts quality silicon nano gel electrolyte
- ✓ Excellent deep discharge recovery capability
- ✓ Deep cycle performance: up to 3300

### Dimensions & Weight

### Technical Specifications

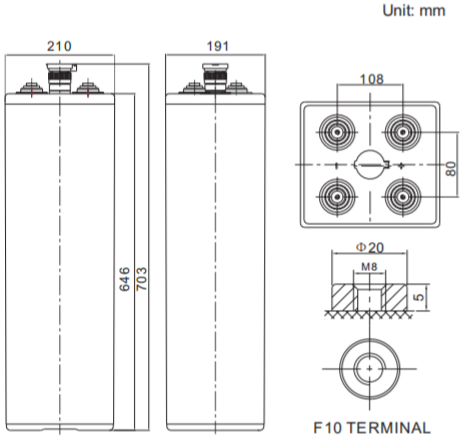

Length	191±1mm (7.52 inches)
Width	210±1mm (8.27 inches)
Height	646±1mm (25.4 inches)
Total Height	703±1mm (27.7 inches)
Torque Value	10~12 N*m

Cells Per Unit	1
Voltage Per Unit	2
Nominal Capacity	800Ah@10hr-rate to 1.85V per cell @25°C
Weight	Without Electrolyte 47.6kg/With Electrolyte 64.3kg
Internal Resistance	Approx. 0.28 mΩ
Terminal	F10(M8)
Max. Discharge Current	3200A (5 sec)
Design Life	20 years (floating charge)
Maximum Charging Current	120.0 A
Reference Capacity	C24 957.6AH C48 1077.3AH C72 1131.2AH C100 1157.1AH C120 1180.2AH C240 1200.0AH
Float Charging Voltage	2.23 V~2.25 V @ 25°C Temperature Compensation: -3mV/°C/Cell
Cycle Use Voltage	2.40 V~2.45 V @ 25°C Temperature Compensation: -4mV/°C/Cell
Operating Temperature Range	Discharge: -15°C~50°C Charge: 0°C~40°C Storage: -15°C~50°C
Normal Operating Temperature Range	25°C ±5°C
Self Discharge	Valve Regulated Lead Acid (VRLA) batteries can be stored for up to 6 months at 25°C and then recharging is recommended. Monthly Self-discharge ratio is less than 3.5% at 25°C. Please charged batteries before using.
Container Material	A.B.S. UL94-HB, UL94-V0 Optional.

### Battery Discharge Table

Discharge Constant Current per Cell (Amperes at 25° C)

F.V/ Time	30min	1h	2h	3h	4h	5h	6h	8h	10h	20h
1.90V	425.7	337.4	237.9	181.4	143.6	127.7	111.7	87.18	74.76	42.99
1.87V	475.9	372.0	255.2	193.1	151.6	135.0	118.4	91.26	78.12	44.91
1.83V	545.1	415.3	276.9	206.5	159.6	141.1	122.6	95.33	81.48	46.86
1.80V	605.6	449.9	287.2	212.6	162.8	144.4	126.0	97.78	84.00	48.30
1.75V	674.9	481.9	300.2	219.4	165.5	147.0	128.5	99.41	85.68	49.26
1.70V	744.1	497.5	308.9	224.6	168.4	149.3	130.2	100.2	86.52	49.76
1.65V	767.4	528.6	319.3	230.2	170.8	151.3	131.9	101.0	87.36	50.24
1.60V	800.3	546.8	331.4	237.9	175.6	154.6	133.6	101.9	88.20	50.72

Discharge Constant Power per Cell (Watts at 25° C)

F.V/ Time	30min	1h	2h	3h	4h	5h	6h	8h	10h	20h
1.90V	814.7	647.8	460.0	352.7	281.1	251.0	220.9	174.4	152.4	87.61
1.87V	896.5	703.4	487.8	372.9	296.3	264.9	233.5	181.7	158.9	91.36
1.83V	1004	766.9	519.1	394.0	310.7	275.9	241.1	188.2	164.6	94.63
1.80V	1097	818.2	536.5	404.5	316.6	281.8	247.0	192.3	168.7	96.98
1.75V	1190	854.7	553.9	414.0	320.8	285.9	251.2	194.7	171.1	98.38
1.70V	1276	863.4	567.8	422.6	325.9	289.8	253.7	196.4	172.7	99.31
1.65V	1298	901.7	583.5	431.4	330.1	293.0	256.2	198.0	173.6	99.79
1.60V	1314	929.5	597.4	442.1	338.5	298.3	257.9	198.8	174.4	100.25

## OPzS Deep Cycle Tubular Flooded Battery 80PzS800

### Performance Characteristics

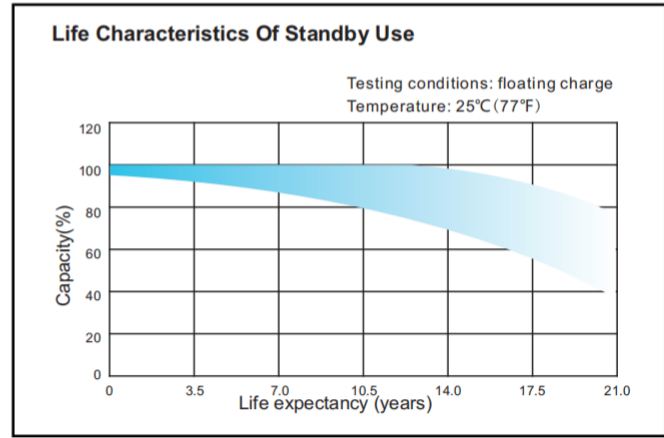
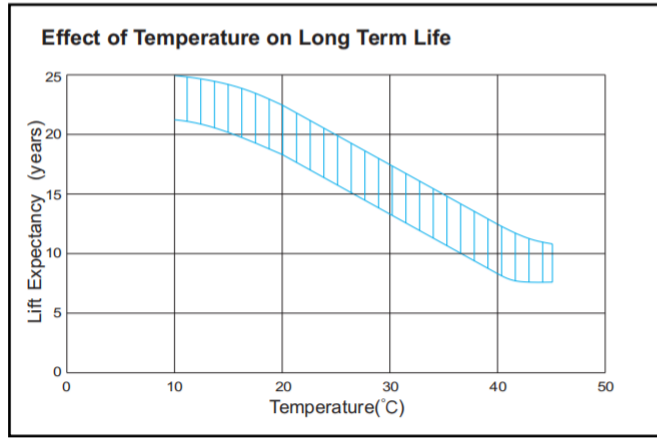
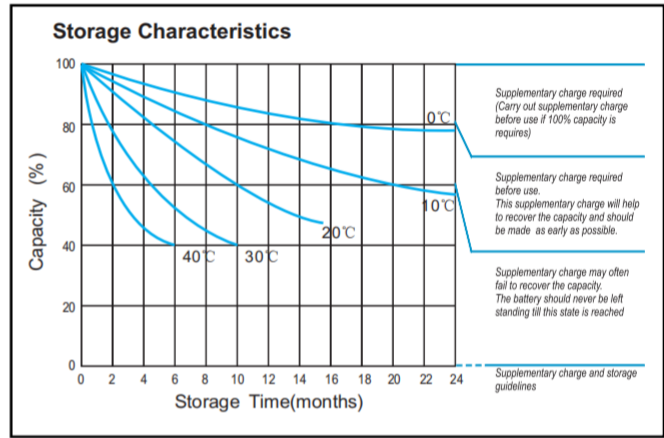
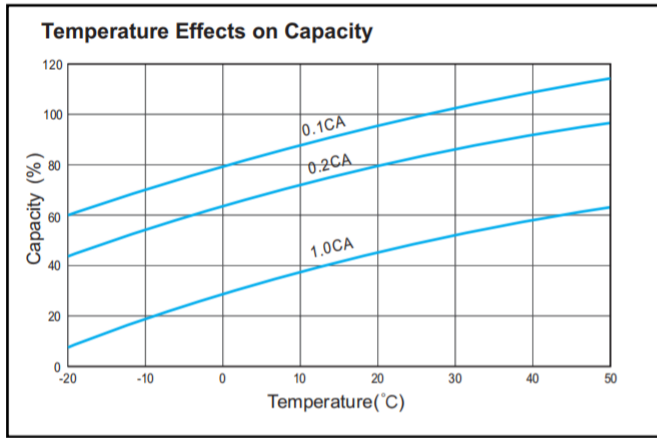
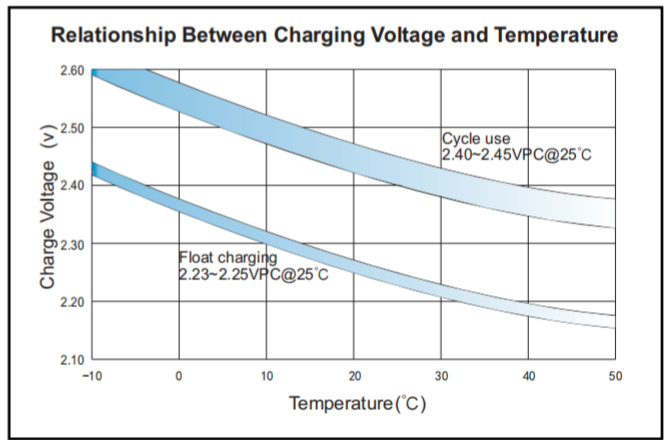
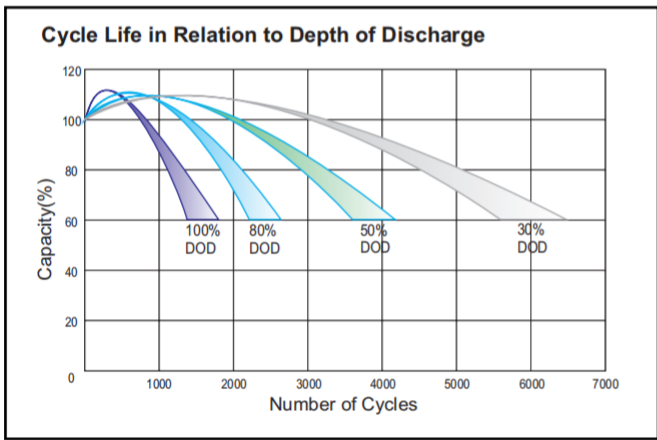
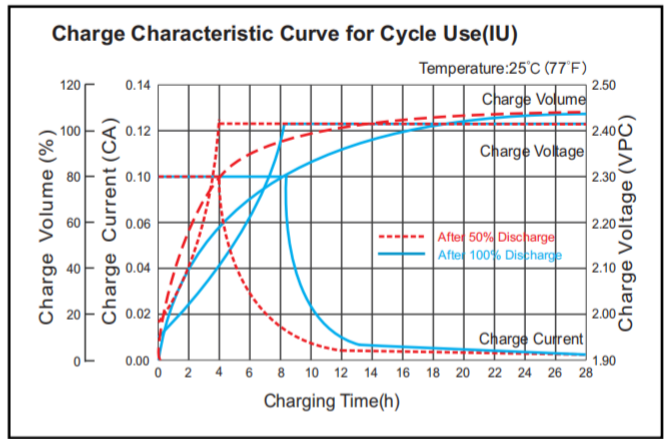
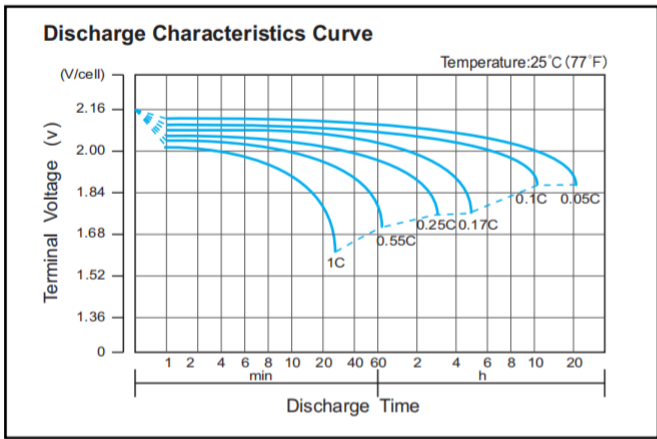

**Note:** The above data are average values, and can be obtained within 3 charge/discharge cycles. These are not minimum values. Cell and battery designs/specifications are subject to modification without notice. Contact **CSBattery** for the latest information.

Add: Building Evolution, Xingdong industry Park, NO.61, Liuxian 2nd Road, Baoan, Shenzhen, China.

Tel: +86-755-29123661 Email: Sales@CSBattery.cn, Support@CSBattery.cn

Website: [www.CSBattery.cn](http://www.CSBattery.cn)