

OPzS Deep Cycle Tubular Flooded Battery 120PzS1500

CSBattery OPzS series is flooded Lead Acid battery that adopts Tubular Plate technology to offer high reliability and performance. The Battery is designed and manufactured according to standards and with DIN40736-2/IEC60896-11 positive spine and patent formula of die-casting active material. OPzS series exceeds standard values with more DIN40736-2/IEC60896-11 than 20 years floating design even more suitable for life at 25°C and is cyclic use(PV/solar, traction etc) under extreme operating conditions.

2V
1500Ah

Flooded
Technology

Tubular
Plate



Applications

- Solar & Wind Power system
- Nuclear power station
- Telecom backup power supply
- energy saving requirements
Emergency Power System

General Features

- ✓ It can discharge at -40°C~70°C, Charge at 0-50°C
- ✓ Long life expectancy of 20+ years in floating condition
- ✓ Adopts quality silicon nano gel electrolyte
- ✓ Excellent deep discharge recovery capability
- ✓ Deep cycle performance: up to 3300

Dimensions & Weight

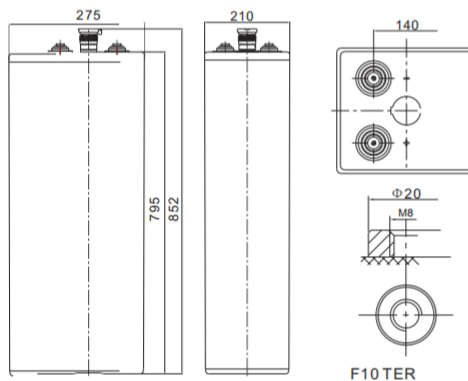

Length	275±1mm (10.8 inches)
Width	210±1mm (8.27 inches)
Height	795±1mm (31.3 inches)
Total Height	852±1mm (33.5 inches)
Torque Value	10~12 N*m

Technical Specifications

Cells Per Unit	1
Voltage Per Unit	2
Nominal Capacity	1500Ah@10hr-rate to 1.85V per cell @25°C
Weight	Without Electrolyte 83.5kg/With Electrolyte 113.5kg
Internal Resistance	Approx. 0.21 mΩ
Terminal	F10(M8)
Max. Discharge Current	5000A (5 sec)
Design Life	20 years (floating charge)
Maximum Charging Current	150.0 A
Reference Capacity	C24 1795.5AH C48 2019.9AH C72 2120.9AH C100 2169.6AH C120 2213.0AH C240 2250.0AH
Float Charging Voltage	2.23 V~2.25 V @ 25°C Temperature Compensation: -3mV/°C/Cell
Cycle Use Voltage	2.40 V~2.45 V @ 25°C Temperature Compensation: -4mV/°C/Cell
Operating Temperature Range	Discharge: -15°C~50°C Charge: 0°C~40°C Storage: -15°C~50°C
Normal Operating Temperature Range	25°C±5°C
Self Discharge	Valve Regulated Lead Acid (VRLA) batteries can be stored for up to 6 months at 25°C and then recharging is recommended. Monthly Self-discharge ratio is less than 3.5% at 25°C. Please charged batteries before using.
Container Material	A.B.S. UL94-HB, UL94-V0 Optional.

Battery Discharge Table

Discharge Constant Current per Cell Amperes at 25°C

F.V/ Time	30min	1h	2h	3h	4h	5h	6h	8h	10h	20h
1.90V	798.1	632.7	446.1	340.0	269.3	239.4	209.5	163.5	140.2	80.61
1.87V	892.2	697.6	478.6	362.0	284.3	253.2	222.1	171.1	146.5	84.21
1.83V	1022	778.7	519.1	387.2	299.3	264.6	230.0	178.7	152.8	87.86
1.80V	1136	843.6	538.6	398.6	305.2	270.7	236.3	183.3	157.5	90.56
1.75V	1265	903.6	562.9	411.3	310.3	275.6	241.0	186.4	160.7	92.36
1.70V	1395	932.8	579.1	421.1	315.7	279.9	244.1	187.9	162.2	93.30
1.65V	1439	991.2	598.6	431.6	320.2	283.8	247.3	189.4	163.8	94.20
1.60V	1501	1025	621.3	446.0	329.2	289.8	250.4	191.0	165.4	95.10

Discharge Constant Power per Cell (Watts at 25°C)

F.V/ Time	30min	1h	2h	3h	4h	5h	6h	8h	10h	20h
1.90V	1528	1215	862.5	661.2	527.1	470.6	414.2	326.9	285.7	164.3
1.87V	1681	1319	914.6	699.2	555.6	496.7	437.9	340.7	297.9	171.3
1.83V	1883	1438	973.3	738.8	582.5	517.3	452.0	352.9	308.6	177.4
1.80V	2058	1534	1006	758.5	593.6	528.4	463.1	360.5	316.2	181.8
1.75V	2232	1603	1039	776.3	601.5	536.1	470.9	365.1	320.8	184.5
1.70V	2393	1619	1065	792.4	611.0	543.4	475.7	368.2	323.9	186.2
1.65V	2434	1691	1094	808.9	618.9	549.4	480.4	371.2	325.4	187.1
1.60V	2463	1743	1120	828.9	634.7	559.3	483.5	372.8	326.9	188.0

OPzS Deep Cycle Tubular Flooded Battery 12OPzS1500

Performance Characteristics

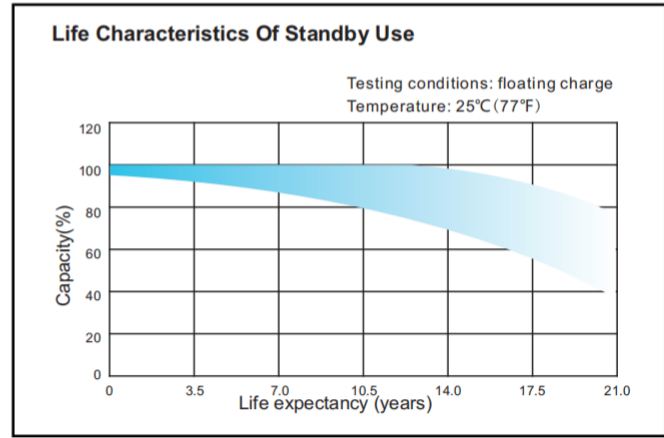
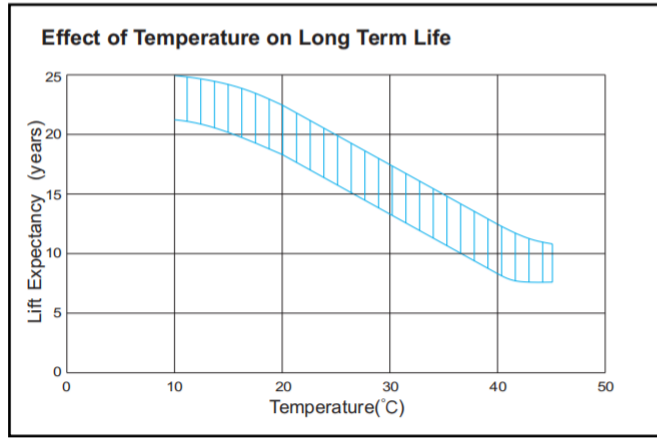
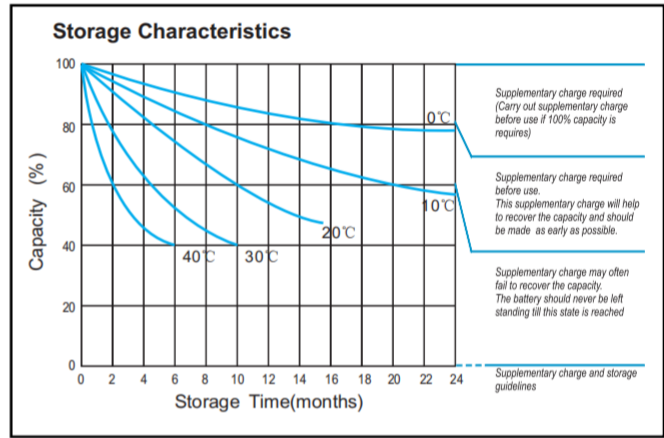
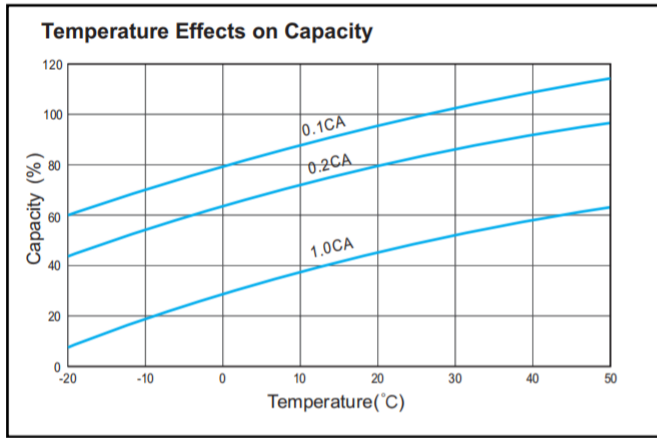
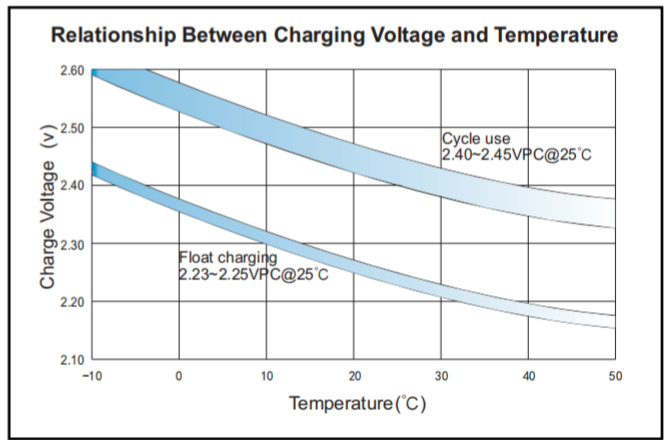
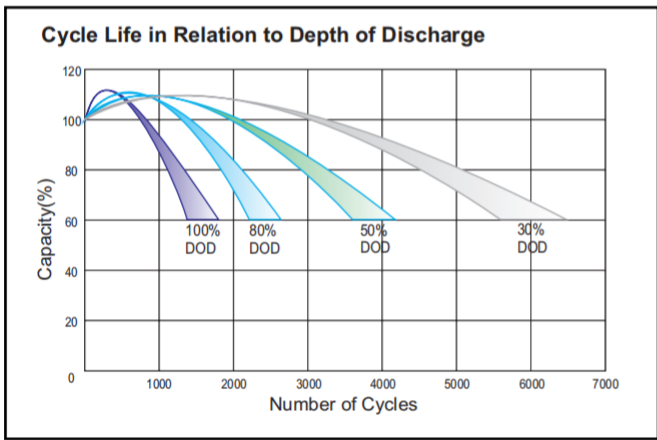
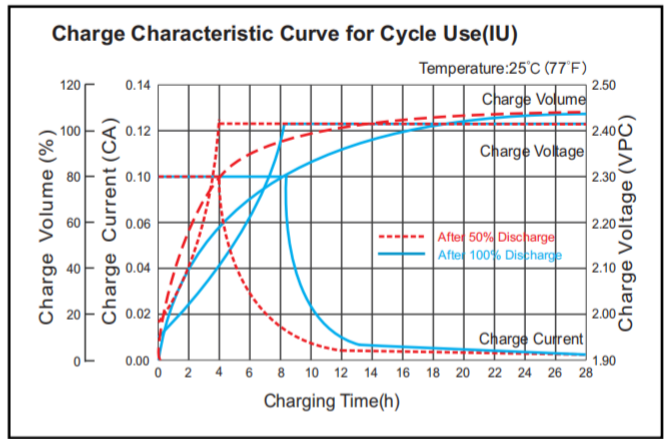
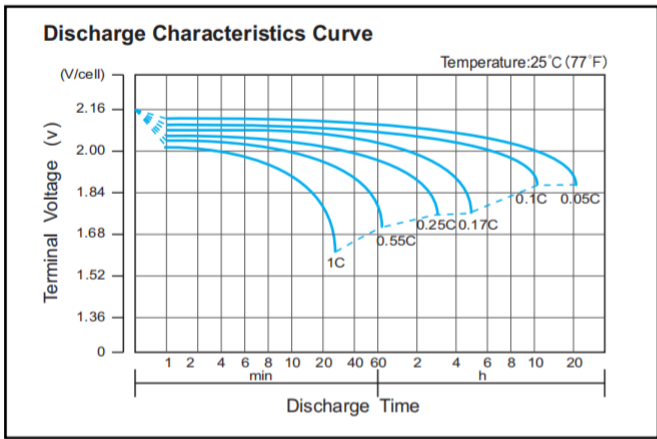

Note: The above data are average values, and can be obtained within 3 charge/discharge cycles. These are not minimum values. Cell and battery designs/specifications are subject to modification without notice. Contact **CSBattery** for the latest information.

Add: Building Evolution, Xingdong industry Park, NO.61, Liuxian 2nd Road, Baoan, Shenzhen, China.

Tel: +86-755-29123661 Email: Sales@CSBattery.cn, Support@CSBattery.cn

Website: www.CSBattery.cn