

## High-Temp Long Life GEL Deep Cycle Battery HTB12-100

HTB series uses the newly developed nano gel electrolyte with super-C additive plus heavy duty plates design inside. The HTB series has a long service life and can provide optimum and reliable service under extreme condition such as high temperature and frequent power failure, This series is highly suited for tropical area in outdoor applications such as Telecom BTS stations and Off-grid PV system.

12V  
100Ah

GEL  
Technology

Deep  
Cycle



### COMPLIED STANDARDS

IEC 60896-21/22 JIS C8704  
IEC61427 BS6290 part4  
GB/T 19638 CE/ISO

### Applications

- BTS Stations
- Solar & Wind energy system
- UPS system
- Telecom systems
- Wheel chair, Golf Car

### General Features

- ✓ Able to operate at 40-60°C
- ✓ DOD 50% 1500 times Cycles
- ✓ Integrated design to ensure the best Uniformity and reliability
- ✓ Long life and high stability under high temp. environment (no air-con needed)
- ✓ Use super-C additives: Deep discharge recovery capability

### Dimensions & Weight

Length(mm)	307±1
Width(mm)	169±1
Height(mm)	211±1
Total Height(mm)	216±1
Weight(kg)	30.5±3%

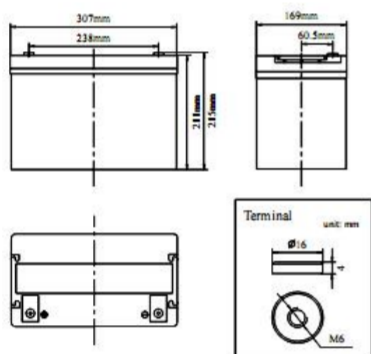

### Technical Specifications

Nominal Voltage		12V (6 cells per unit)
Design Floating Life @25°C		20 Years
Nominal Capacity @25°C (20 hour rate@5.0A,10.8V)		100Ah
Capacity @25°C	10hour rate (9.0A,10.8V)	90Ah
	5 hour rate (15.9A,10.5V)	79.5Ah
	1 hour rate (55.6A,9.6V)	55.6Ah
Internal Resistance	Full Charged Battery@25°C	≤5.3mΩ
Ambient Temperature	Discharge	-25°C~60°C
	Charge	-25°C~60°C
	Storage	-25°C~60°C
Max.Discharge Current@25°C		540A(5s)
Capacity affected by Temperature (10 hour)	40°C	108%
	25°C	100%
	0°C	90%
	-15°C	70%
Self-Discharge@25°C per Month		3%
Charge (Constant Voltage) @25°C	Standby Use	Initial Charging Current Less than 22.5A Voltage 13.6-13.8V
	Cycle Use	Initial Charging Current Less than 22.5A Voltage 14.4-14.9V

### Battery Discharge Table

#### Discharge Constant Current per Cell (Amperes at 25°C)

F.V/Time	15min	30min	45min	1h	2h	3h	5h	8h	10h	20h	100h
1.60V	128.7	82.0	60.5	55.6	35.3	24.8	16.8	11.1	9.9	5.4	1.20
1.65V	126.4	80.5	59.4	54.5	34.6	24.3	16.5	10.9	9.7	5.3	1.18
1.70V	124.0	79.0	58.3	53.5	34.0	23.9	16.2	10.7	9.5	5.2	1.15
1.75V	121.7	77.5	57.2	52.5	33.3	23.4	15.9	10.5	9.4	5.1	1.13
1.80V	117.0	74.5	55.0	50.5	32.1	22.5	15.3	10.1	9.0	5.0	1.11

#### Discharge Constant Power per Cell (Watts at 25°C)

F.V/Time	15min	30min	45min	1h	2h	3h	5h	8h	10h	20h	100h
1.60V	247.7	157.8	116.5	106.9	67.9	47.6	32.4	21.4	19.1	10.4	2.31
1.65V	243.2	154.9	114.3	105.0	66.6	46.8	31.8	21.0	18.7	10.2	2.26
1.70V	238.7	152.0	112.2	103.0	65.4	45.9	31.2	20.6	18.4	10.0	2.22
1.75V	234.2	149.1	110.1	101.1	64.2	45.0	30.6	20.2	18.0	9.8	2.18
1.80V	225.2	143.4	105.9	97.2	61.7	43.3	29.5	19.4	17.3	9.6	2.14

**Note:** The above data are average values, and can be obtained within 3 charge/discharge cycles. These are not minimum values. Cell and battery designs/specifications are subject to modification without notice. Contact **CSBattery** for the latest information.

## High-Temp Long Life GEL Deep Cycle Battery HTB12-100

### Performance Characteristics

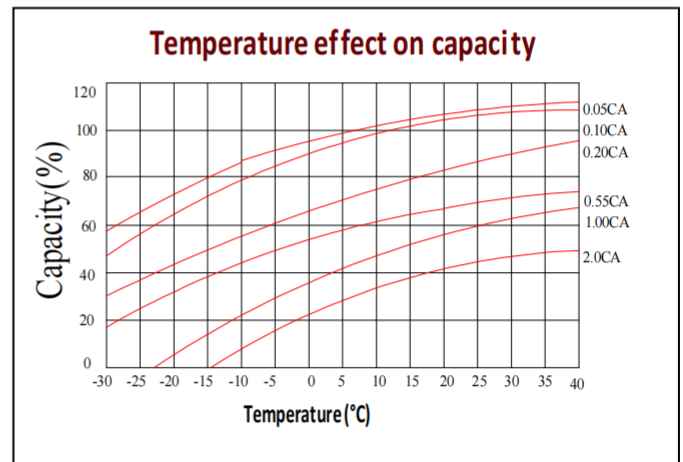
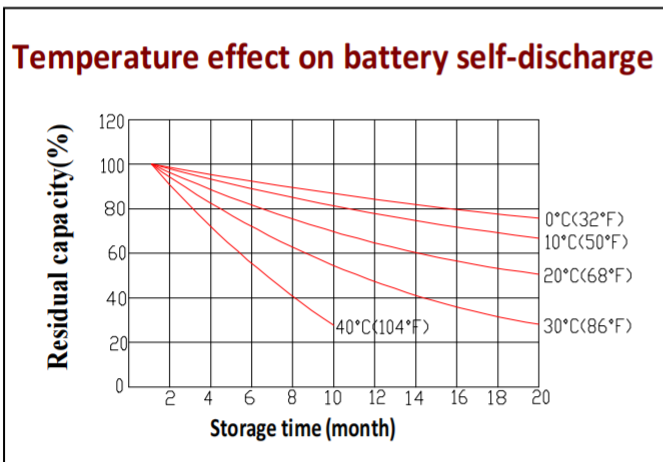
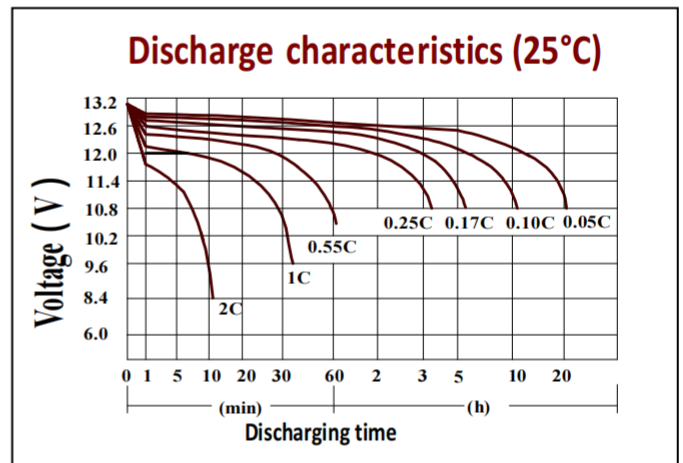
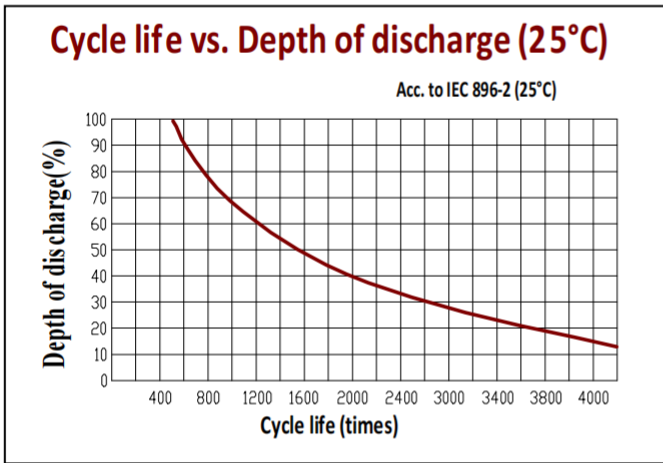
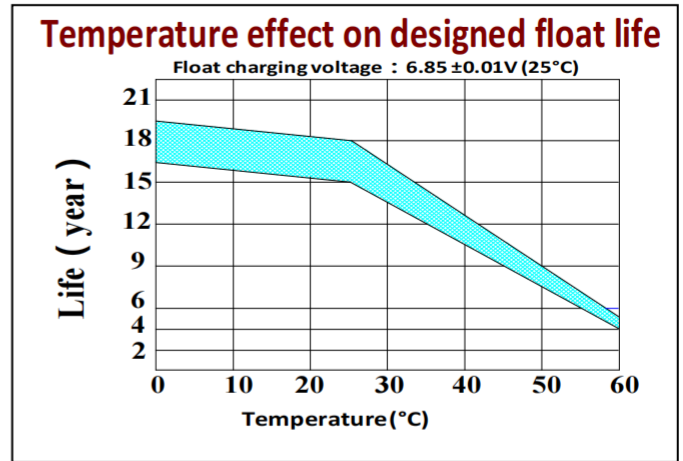
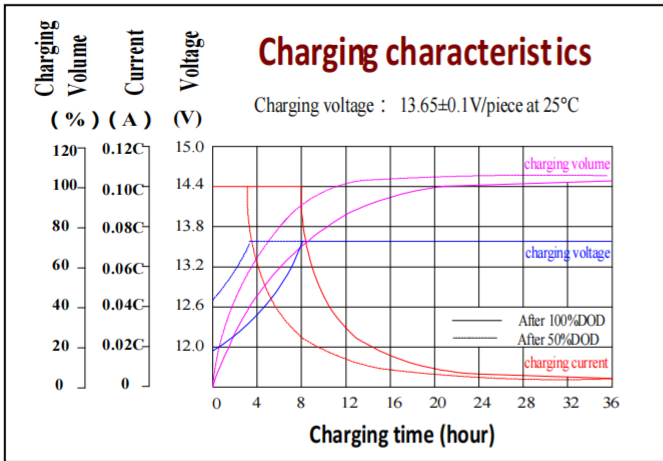

### Battery Construction

Component	Positive plate	Negative plate	Container & Cover	Safety valve	Terminal	Separator	Electrolyte	Pillar seal
Features	Thick high Sn low Ca grid with special paste	Balanced Pb-Ca grid for improved recombination efficiency	Fire resistant ABS (UL94-V0 optional)	Flame Si-Rubber and aging resistance	Female Copper Insert M8	Advanced PVC /AGM separator for high pressure cell design	Silicon Gel	Two layers epoxy resin seal

Add: Building Evolution, Xingdong industry Park, NO.61, Liuxian 2nd Road, Baoan, Shenzhen, China.

Tel: +86-755-29123661 Email: Sales@CSBattery.cn, Support@CSBattery.cn

Website: www.CSBattery.cn